



Illuminated Obstacle Indicator

Cat XLP940WEWE

Instruction Manual

1 Specifications

| | |
|---------------------------------------|-----------------------------------------------------------------------------------------------------------------------------------------------------------------------|
| Supply voltage | 100-240V a.c. |
| Max power | 1.3W |
| Stand-by power | 0.5W |
| Light source | LED |
| Terminal capacity | 1 x 2.5mm ² or 2 x 1.5mm ² |
| IP rating | IP41 |
| Storage temperature | 0°C to +35°C |
| Operating temperature | 0°C to +35°C |
| Resistant to the following agents | Hexane, methylated spirits, soapy water, diluted ammonia, diluted pure bleach (10%), glass cleaning substance, pre-impregnated wipes, diluted hydrogen peroxide (35%) |
| Not resistant to the following agents | Acetone, tar remover, trichloroethylene |

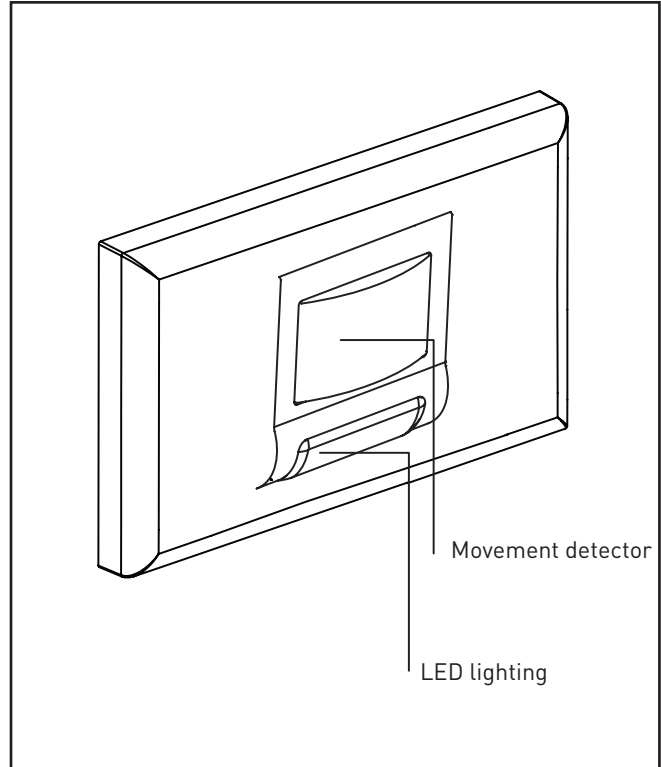

2 Operation

If the ambient light level is below 2.5 lux and movement is detected within the field of view, the indicator light turns on for 30 seconds and a short sound signal is emitted. The sound feature can be enabled or disabled using the switch located underneath the front cover of the mechanism.

A graphical representation of how the unit operates is shown below.

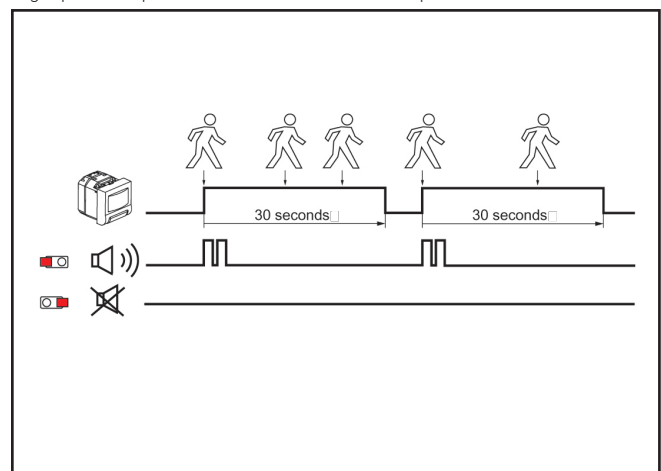
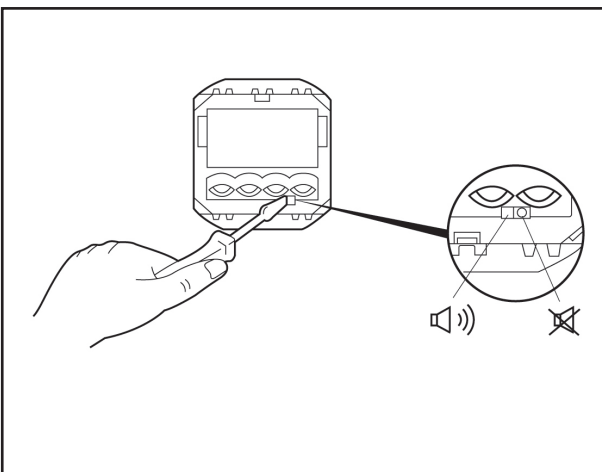

2 Operation continued

Horizontal detection

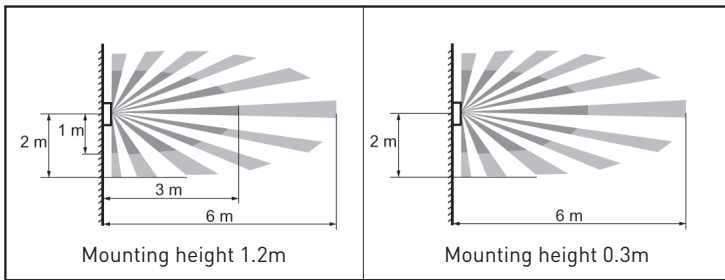

Vertical detection

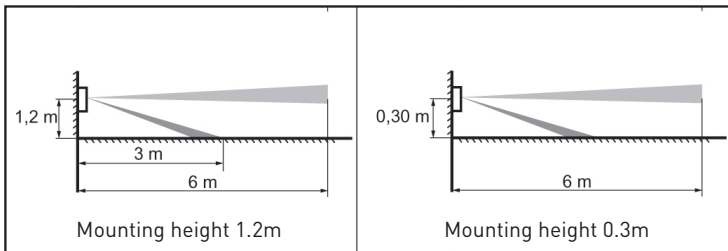

3 Mechanism Dimensions

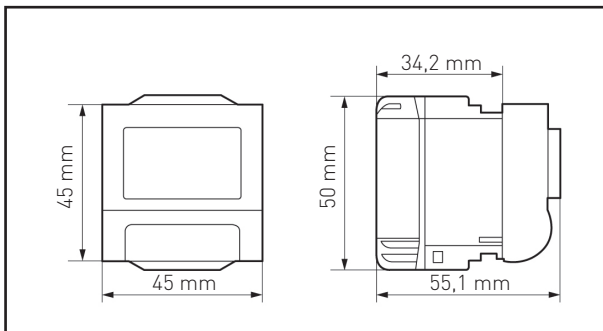

4 Wiring

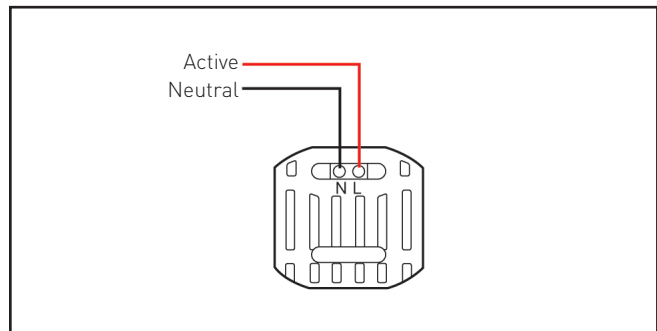

5 Warning

This product must only be connected to the mains supply by a qualified electrician.

Warranty

HPM Cat XLP940WEWE is warranted as here and after appears, against faulty material and/or workmanship for a period of one year from the day of purchase. The obligation of the manufacturer under this warranty is limited to servicing and replacing defective parts when the unit is returned to the authorised place of purchase. To obtain warranty repair, the purchase receipt should be returned with the product. This warranty becomes void on any unit which has been tampered with or damaged by accident, short circuited, loaded beyond rating or damaged otherwise by improper operation. The warranty is also conditional on the unit being installed by a licensed electrical contractor. All other warranties, whether expressed or implied, and whether arising by operation of law or otherwise are hereby excluded.

Customer Service

For all customer service and technical support please call Monday to Friday during business hours.

HPM Legrand Australia
1300 369 777
www.hpm.com.au

HPM Legrand - New Zealand
0800 476 009
www.hpm.co.nz

Legrand Australia Pty Ltd
ABN: 31 000 102 661

A Group Brand |  **legrand**[®]